



PETROL BRUSH CUTTER & GRASS TRIMMER

RACDBT51ES

USER GUIDE

CAUTION: Read this manual before use this machine!

CONTENTS

1. SAFETY INSTRUCTIONS.....	3
2. SAFETY SYMBOLS.....	7
3. PRODUCT DESCRIPTION.....	9
4. TECHNICAL INFORMATION.....	10
5. ASSEMBLY.....	11
6. FILLING FUEL TANK.....	13
7. OPERATION	14
8. MAINTENANCE AND STORAGE.....	17
9. DISPOSAL.....	19
10. TROUBLESHOOTING.....	20
11. DECLARATION OF CONFORMITY.....	21
12. WARRANTY.....	22
13. PRODUCT FAILURE.....	23
14. WARRANTY EXCLUSIONS.....	24

1. SAFETY INSTRUCTIONS

- **WARNING!** When using this type of tool, basic precautions should always be followed to reduce the risk of fire and injury.
- Read all instructions carefully before attempting to use this product and retain these instructions. Be familiar with all the operations described in these operating instructions. This product must be operated by experienced users.
- Inexperienced users shall first have training in all operations with a professional.
- If you are giving this machine to others, please also provide them with this instruction manual.
- Read all markings affixed on the product (symbols, stickers, technical data, etc.). The symbols are explained in this manual.
- Use this machine as described in this instruction manual. It is strictly forbidden to use this tool for applications other than those described in this manual.
- Failure to follow these instructions can result serious injuries and, in some cases, death.
- This product is intended for private domestic use only. Do not use it for commercial purposes.
- Never let people unfamiliar with these instructions or children use this product.
- National regulations may limit the use of the machine.
- People under the age of 18 must not use this product
- Keep in mind that the operator or user is responsible for accidents or risks to other persons or their property.
- **WARNING:** Do not use of the unit when tired, ill or under the influence of alcohol or other drugs.
- Do not use the tool if you are not in an adequate physical condition.
- This tool is intended for outdoor use. Never use it indoors.
- Secure the machine during transport to prevent loss of fuel, damage, or injury; always install the protection device on the blade, check the cap of the fuel tank, and do not transport the tool upside down.
- Keep people and animals away from the work area. Children and people who don't know how to use this tool should not touch it and handle it.
- **WARNING:** Keep people at least 15 m from the machine during operation.
- Use the product only under daylight or under good artificial light.
- When using the machine, always wear full protective equipment including a protective helmet, protective mask, hearing protection, ocular protection, gloves, slip-resistant foot protection and protective clothing. The protective equipment shall be in conformity with European norms.
- Wear appropriate clothing. Do not wear loose or unbuttoned clothes. Do not wear jewelry that may meet moving parts. If you have long hair, tie it down and wear an appropriate safety helmet.
- Do not operate the product with damaged guards or shields not in place.
- Always keep hands and feet far away from the cutting parts and especially when switching ON/OFF the tool.
- Do not use the tool in an area where ventilation is poor. Gas emissions can cause injury.
- Do not work when it rains and in bad weather. Do not use the tool in damp locations.
- Do not use the tool in the presence of flammable liquids or gases.
- Keep the work area clear. Before working, inspect the work area and remove any materials or objects that could cause accidents.
- Do not force the tool.
- Use only accessories and guards supplied or recommended by the manufacturer. The use of non-recommended accessories (e.g. metal multi-piece pivoting chains and flail blades) may result in an accident. Ask your dealer for advice.
- Keep firm footing and balance during operation. Always use the harness provided.
- Have a correct working posture; stay standing, do not lean. The working positions should be changed regularly.
- Always inspect the machine before and after operation. If the tool is damaged or faulty, stop using the tool and bring it to an authorized service for inspection and repair.
- Concentrate when using the tool. Look at what you do, make sense, and do not use the tool when you are tired.
- Remove the blade guard before using the tool.
- A damaged part must be properly repaired or replaced by an authorized service center, unless

otherwise specified in this instruction manual.

- Do not use the tool if the switch is not working (if it cannot be turned ON or OFF).
- Immediately stop the tool in the event of a malfunction of the motor or in case of unusual noise.
- Do not use the tool if the starter is damaged.
- Avoid any contact with the cutting attachment during operation; they can cause severe cuts.
- When not in use, the machine must be stored in a dry, locked place out of the reach of children.
- Before using the tool and after any impact, please check for signs of wear or if it is not damaged. If repairs are required, they should be done by a qualified service.
- Always switch off the machine:
 - Every time you leave it unattended.
 - Before inspection and maintenance
 - After hitting a foreign object.
 - When abnormal vibration occurs.
 - During the replacement of parts.
- Always carry the tool by holding the handle, never the blade.
- Do not use the product on a slippery surface.
- Do not use the product on steep, slippery slopes.
- When planning your work schedule, allow enough time for rest. Limit continuous use of the tool. For example, do 30 ~ 40-minute sessions interspersed with a 10 ~ 20-minutes break. Work a maximum of two hours a day.
- If the machine has struck foreign objects, check if the tool is damaged and bring it to repair if necessary.
- Keep handles dry, clean, and free of oil and grease. Oily, greasy grips are slippery and cause loss of control.
- Be careful when using the machine during stormy weather. Do not use the machine during lightning and thunderstorms.
- Warning - When operating the tool, be careful of the emission of exhaust gases, avoid being exposed to these and wear protective equipment.
- For machines with a clutch, check regularly that the cutting attachment stops turning when the engine idles.
- Check the tool before and after use. Check for loose fasteners, fuel leaks and damaged parts, such as cracks in the cutting attachment. If the tool is damaged, if parts are missing or meet some dysfunctions, do not use the tool and bring it to a service agent for inspection and reparation.
- Check the tool after dropping or other impacts to identify any significant defects; if any defects are observed, stop using the tool and bring it to a service agent for inspection and reparation.
- Do not store it in a closed area where fuel vapors can reach an open flame from hot water heaters, furnaces, etc. Store in a locked, well-ventilated area only.
- Never place the machine in any places where there are flammable materials (dry grass, etc.), combustible gases or combustible liquids.
- When the machine is placed in storage for a long time, drain fuel from the fuel tank and carburetor, clean the parts, move the machine to a safe place and confirm that the engine is cooled down.

FUEL HANDLING

- Be very careful when handling fuels. They are flammable and the vapors are explosive.
- Use only an approved container.
- Never remove the fuel cap or add fuel while the machine is on. Turn off the unit and allow the engine and exhaust components to cool before refueling.
- Do not smoke.
- Never refuel inside a room.
- Never store the tool and the fuel tray indoors where there is a naked flame, such as near a water heater.
- If fuel has spilled, do not attempt to start the machine, but rather move it away from the spill before starting to use it. Clean any spills.
- Replace and tighten the fuel tank cap after refueling.
- Follow the instructions in this manual for filling the tool with fuel.

MAINTENANCE AND STORAGE

- Stop the tool and wait until it stops. Make sure all moving parts have come to a standstill.
- Allow the machine to cool before performing inspection, adjustments, maintenance, servicing, and storage.
- Maintenance and cleaning shall always be done after operation. Follow the instructions given in this manual for maintenance, cleaning, and storage.
- Store the tool where fuel vapors will not reach a flame or spark.
- During transport, maintenance, and storage, always install the cover on the metal blade.
- When the machine is stored for a long time, drain the fuel tank, clean the parts. Put the machine in a safe place.

KICKBACK AND RELATED WARNINGS

A kickback is a sudden reaction to a pinched or snagged rotating wheel, backing pad, brush, or any other accessory. Pinching or snagging causes rapid stalling of the rotating accessory which in turn causes the uncontrolled power tool to be forced in the direction opposite of the accessory's rotation at the point of the binding.

Kickback is the result of power tool misuse and/or incorrect operating procedures or conditions and can be avoided by taking proper precautions as given below:

- Never place your hand near the rotating accessory. Accessory may kickback over your hand.
- Do not position your body in the area where the power tool will move if a kickback occurs. Kickback will propel the tool in direction opposite to the wheel's movement at the point of snagging.
- Use special care when working corners, sharp edges etc. Avoid bouncing and snagging the accessory. Corners, sharp edges or bouncing tend to snag the rotating accessory and cause loss of control or kickback.

RESIDUAL RISKS

Even if you use this product in accordance with all safety requirements, the potential risk of injury and damage remains. The following hazards may arise:

- There are harmful health consequences resulting from the emission of vibrations if the product is used for long periods of time or not managed adequately and properly maintained. The vibrations can produce the so-called "white finger" disease. If any of the symptoms of "white finger" syndrome appear, see a doctor immediately. Symptoms of the "white finger" include: numbness, loss of sensitivity, tickling, tingling, pain, loss of strength, color changes, or skin condition. These symptoms usually appear on the fingers, hands, or wrists. The risk increases at low temperatures. To reduce this risk, please wear gloves and keep your hands warm. Limit the operating time.
- There is a risk of hearing loss during prolonged use, in particular if you do not wear hearing protection. Always wear hearing protection and limit the operating time.
- Cuts if no suitable protective clothing is worn.
- Inhalation of particles and exhaust gases if a mask of protection is not worn.
- Contact with projected objects.
- Burns when touching with hot surfaces.

INTENDED USE

This machine can be used as a trimmer with the cutting edge, and as a brushcutter with the cutting blade.

The grass trimmer must be strict and only cut grass or weeds that are not too dense. The brushcutter must be used to cut hard grass, denser weeds, and small branches with a maximum diameter of 10mm.

This machine is not intended to cut bushes or others similar plants requiring the tool to get off the ground. Do not use this tool to work with other materials such as stones, clay soils, etc.

SAFETY INSTRUCTIONS FOR BATTERIES AND CHARGER

1) Batteries

- Never attempt to open for any reason.

- Do not store in locations where the temperature may exceed 40°C (104°F).
- Charge only at ambient temperatures between 4°C and 40°C (39.2°F and 104°F).
- Charge only using the charger provided with the tool.
- Store your batteries in a cool dry place (5°C-20°C/41°F-68°F). Never store batteries in a discharged state.
- It is better for Li-ion batteries to discharge and reload them regularly (at least 4 times a year). The ideal charge for long-term storage of your Li-ion battery is 40% of capacity.
- When disposing of batteries, follow the instructions given in the section “Protecting the environment”.
- Do not cause short circuits. If connection is made between the positive (+) and negative (-) terminal directly or via accidental contact with metallic objects, the battery is short circuited, and an intense current will flow causing heat generation which may lead to casing rupture or fire.
- Do not heat. If batteries are heated to above 100°C (212°F), sealing and insulating separators and other polymer components may be damaged resulting in electrolyte leakage and/or internal short circuiting, leading to heat generation causing rupture or fire. Moreover, do not dispose of the batteries in fire, explosion and/or intense burning may result.
- Under extreme conditions, battery leakage may occur. When you notice liquid on the battery, proceed as follows:
 - Carefully wipe the liquid off using a cloth. Avoid skin contact.
 - In case of skin or eye contact, follow the instructions below:
 - Immediately rinse with water. Neutralize with a mild acid such as lemon juice or vinegar.
 - In case of eye contact, rinse abundantly with clean water for at least 10 minutes.
 - Consult a physician.



Fire hazard! Avoid short-circuiting the contacts of a detached battery. Do not incinerate the battery.











2) Charger



















- Use the charger provided with the tool only to charge the battery.
- Never attempt to charge non-rechargeable batteries.
- Have defective cords replaced immediately.
- Do not be exposed to water.
- Do not open the charger.
- Do not probe the charger.
- The charger is intended for indoor use only.
- This charger can be used by children aged from 8 years and above and persons with reduced physical, sensory, or mental capabilities or lack of experience and knowledge if they have been given supervision or instruction concerning use of the appliance in a safe way and understand the hazards involved.

- Children shall not play with the appliance. Cleaning and user maintenance shall not be made by children without supervision.
- If the supply cord is damaged, it must be replaced by the manufacturer, its service agent, or similarly qualified persons to avoid a hazard.

 **CAUTION:** Do not recharge non-rechargeable batteries.

2. SAFETY SYMBOLS

	Warning symbol
	Wear an equipment of protection including a helmet, protective glasses, hearing protection
	Wear hearing protection
	Wear ocular protection
	Wear protective gloves
	Wear protective and non-skid shoes
	Read the instruction manual
	Risk of projection – keep bystanders away - The distance between the machine and bystanders shall be at least 15 m.
	Do not use saw blades
	Guarantee noise level
	No smoking

	Warning! Cutting elements
	Caution: the accessible surface maybe hot when using the tool
	Keep 15 meters away from other people
	Wait until all machine components have completely stopped before touching them,
	Poisonous fumes or toxic gases
	Do not expose to rain or humidity
	No naked fire near the machine
	Caution! Beware of blade thrust
	GASOLINE+OIL mixed 40:1 - Position: FUEL TANK CAP
	Choke lever - Position: AIR CLEANER COVER
	Fuel pump
	Class II, double isolation (only for charger).
	Do not dispose of old appliances with domestic rubbish.
	Do not expose the charger or the battery to water.
	Do not incinerate the battery or charger.
	Ambient temperature of 40°C max. (only for the battery).
	Battery and charger to be used indoors only.
	Recycling.

3. PRODUCT DESCRIPTION

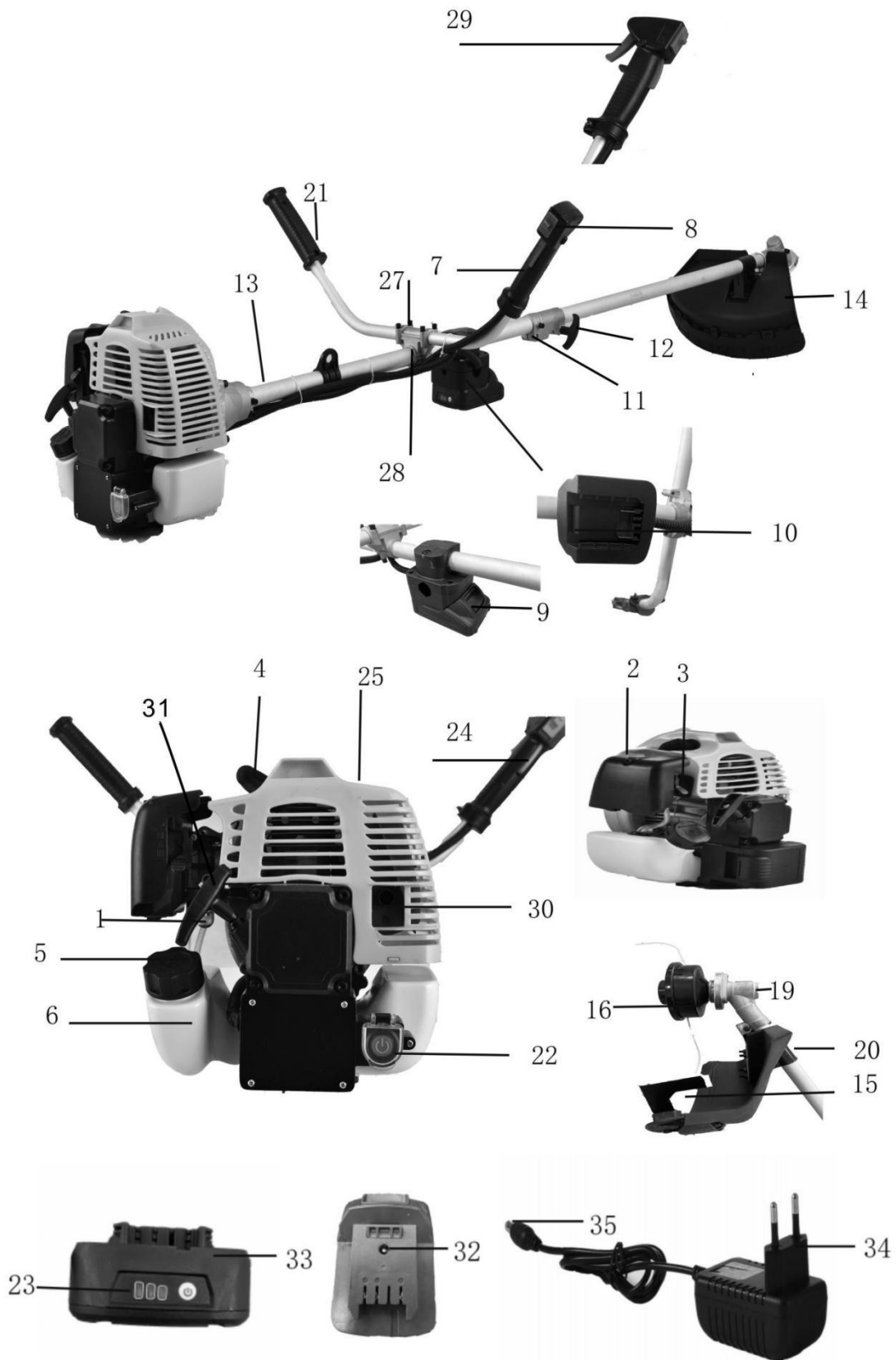

1	Primer Bulb	12	Knob	25	Engine Housing
2	Air Filter Knob	13	Shaft	27	Upper part for attaching the handle
3	Choke Lever	14	Carter of protection	28	Lower part for attaching the handle

4	Spark Plug Cover	15	Trimming Line Cutting Blade	29	Throttle Lever
5	Fuel Tank Cap	16	Trimmer Head W / Line Spool	30	Muffler
6	Fuel Tank	19	Gear Box Housing	31	Recoil starting handle
7	Main Handle	20	Debris Guard Mounting Bracket	32	Charging Port
8	Stop Switch	21	Handle	33	Battery Pack
9	Battery Release Button	22	Electric starting Button	34	Charger
10	Battery Slot	23	Battery Power Indicator	35	Charging Connector
11	Shaft Connection Sleeve	24	Throttle Safety		

4. TECHNICAL INFORMATION

MODEL		RACDBT51ES
	Maximum rotational frequency of the spindle	9500/min
	Idle speed of engine	3000/min
	Measured vibration value	Brush cutter: 7.824m/s ² , K=1.5 m/s ² Grass trimmer: 8.856 m/s ² , K=1.5 m/s ²
	Sound pressure level	<u>Grass trimmer</u> - Idling: 93dB - Racing: 108dB - Uncertainty K = 3 dB <u>Brush cutter</u> - Idling: 81,1dB - Racing: 99,4dB - Uncertainty K = 3 dB
	Guaranteed sound power level	112 dB(A)
	Line Max. Cutting Path /Diameter of line	43 cm (φ2.4mm)
	Metal blade (Type/Diameter)	3-tooth Ø255xØ25.4x1.4mm
	Weight	7.31 kg
	Engine	Name of engine
Type		Air-cooled; 2 cycles;
Displacement		52 cm ³
Maximum output		1,45kW/7500/min
Method of starting		Recoil, electric starting
Fuel used		Gasoline mixed with lubricating oil (ratio of 40:1)
Fuel tank capacity		1250 ml
Battery		JCB2001-Li20 20V d.c. 2Ah 40Wh Li-ion battery
Charger		CL10072000500G Input 100-240V~,50-60Hz, 0.4A Output 20V d.c. 0.5A, 10W

5. ASSEMBLY

HANDLE INSTALLATION

Remove the upper part of the handle attachment (1) by unscrewing the four screws. Install the operating handles (3 and 5). The right-hand grip (3) is equipped with engine controls, the trigger of the right-hand grip should be directed toward the gearbox.

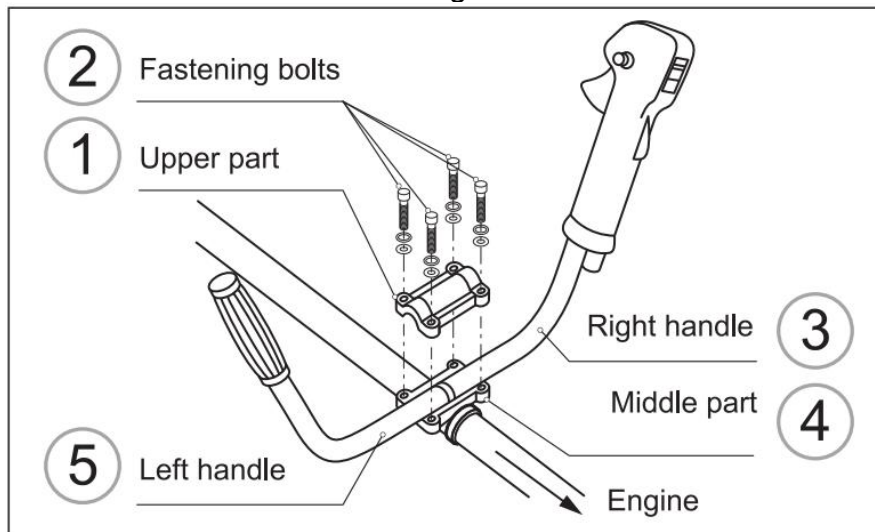

Install the rod assembly to the engine using four screws.
Adjust the comfortable position of the handles and eyelets for the shoulder strap.
Hook the shoulder strap to the eyelet.

Mounting the tube

- Pull out the locking pin (a) and press the lower part of the shaft (b) downward until the locking pin engages. The bolt (a) is in the right position when it is fully seated in the bore.
- Tighten the knob (d) securely.

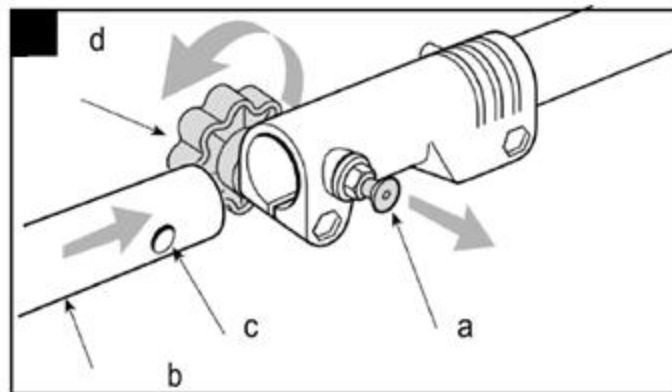

Assembly of the carter of protection

- Install the carter of the protection on mounting plate; make sure that the holes are aligned.
- Screw the carter of protection with the 2 screws.

NOTE: the carter of protection shall be always installed.

Assembly of the 3-teeth blade (for brush cutting)

Warning - sharp edges; wear gloves when manipulate the blade.

- Insert a metal locking tool in the hole on the side of the drive sprocket and on the drive.
- Remove the retaining nut, the cover bell and the plate.
- Install in the following order, on the shaft: the blade, the plate, the cover bell.
- Screw with the retaining nut.
- Remove the metal locking tool.

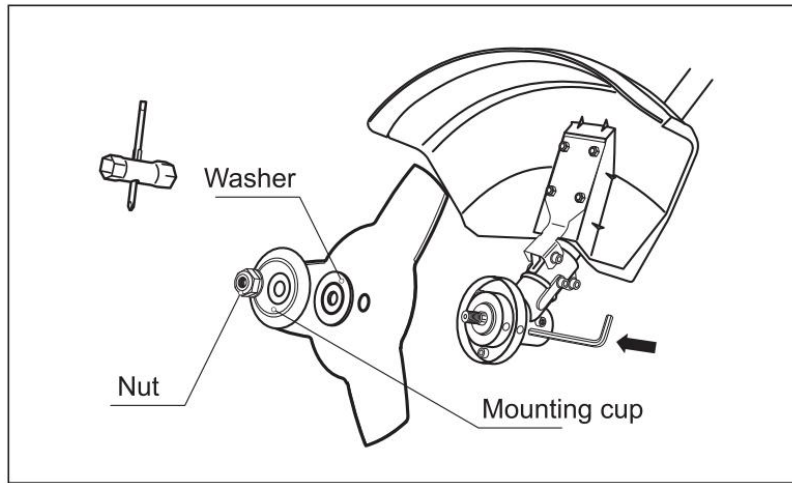

To disassemble the blade, insert a metal locking tool in the hole on the side of the drive sprocket and on the drive. Loosen the retaining nut and then remove all elements.

NOTE:

After installation, always check if the installation is correct. If blade is not installed, it will vibrate excessively and can cause injury. When operation, if there is abnormal vibration, immediately stop the tool and check the installation.

Assembly of the nylon cutting head (for grass trimming)

- Insert a metal locking tool in the hole on the side of the drive sprocket and on the drive shaft.
- Remove the retaining nut, the cover bell, and the plate.
- Install and screw the nylon cutting head.
- Remove the metal locking tool.

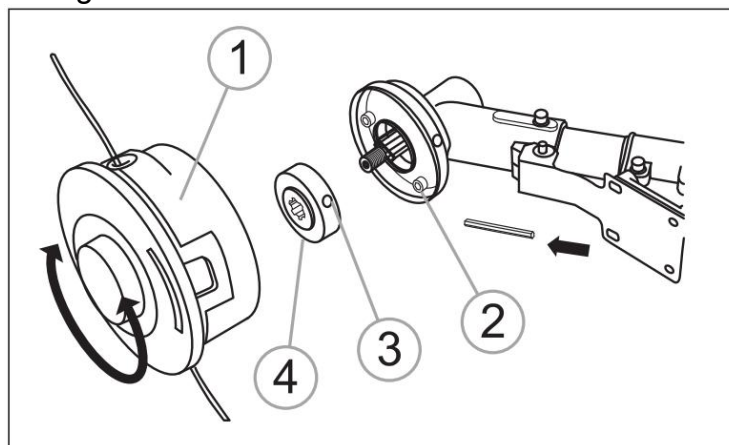

To disassemble the nylon cutting, head, insert a metal locking tool in the hole on the side of the drive sprocket and on the drive. Unscrew the nylon cutting to remove it.

Installing the harness

- Put on the harness.
- If necessary, adjust the bands of the harness to have the blade parallel to the ground when standing in your normal working position to provide you most effectiveness and comfort on operating the machine.
- Install the hook on the main unit to attach the harness.

Quick release mechanism

Pull the strip to release the machine from you in the case of emergency.



6. FILLING THE FUEL TANK

WARNING: When filling the tank:

- The tool must always be stopped and cooled.
- Never smoke during refueling. It must not have flames or sparks near the fuel.
- Before refueling, allow the tool to cool completely. Do not attempt to refuel when the engine is hot.
- If fuel has been spilled, immediately stop refueling and do not start the engine. Clean up the spill and fill the machine in another location
- Never fill the fuel tank to the flange; there is a risk of overflow.
- Do not refuel in a closed and unventilated area.

The fuel used for this tool is a mixture of unleaded gasoline and registered engine lubricant. When mixing gasoline with oil, use only gasoline that does not contain ethanol or methanol.

Unleaded gasoline is a quality gasoline type. This will help to avoid damaging the fuel lines of the engine and other engine parts.

The recommended mixing ratio is 40:1 (make sure the mixing ratio is correct before filling the product).

a. Mixing

- Mix in a clean, empty container (supplied).
- Pour the oil into the container.
- Pour the fuel into the tank. Mix the mixture long enough (more than one minute) to get a good combination.

b. Filling the fuel tank

- Unscrew the fuel tank cap and remove it.
- Fill the tank slowly with the mixture. Do not exceed the maximum capacity (fill to 80% of its capacity preferably).
- Replace the cap on the fuel tank and tighten it.
- Wipe any spillage around the unit if necessary

NOTE: To avoid damage and accidents, DO NOT USE OTHER MIXTURES AND OTHER TYPES OF OIL/ PETROL

c. Storage of fuel

The fuel must be kept in a clean and safe container and always closed.

If you are not using the product for a long time, remove the fuel mixture and add it to a container.

Do not leave the fuel for a long time in the product. The fuel may clog the carburetor and the engine will not operate properly.

d. Disposal of fuel

When the fuel is no longer used or worn, please dispose of it in an authorized location. Check local laws regarding disposal of fuels.

7. OPERATION

1) CHARGING THE BATTERY PACK

IMPORTANT: The battery pack is not fully charged at the factory. Before attempting to charge them, thoroughly read all the safety instructions.

- 1) Be assured that the charger you use is applicable to the battery pack.
- 2) Insert the charger into 110-240V~, 50/60Hz outlet. The indicator light (3) become to green light to show the power is connected.
- 3) Insert the end of charger (1) into the slot of battery (2). Make sure the contact with the charger is correct.
- 4) When charging the indicator light (3) becomes a red light.
- 5) When fully charged the indicator light (3) becomes green light.



- 6) Frequently monitor the charger and battery pack while connected.
- 7) Unplug the charger and disconnect it from the battery pack when finished.
- 8) Allow the battery pack to cool completely before using it.
- 9) Store the charger and battery pack indoors, out of reach of children.



Note: If the battery does not fit properly, disconnect it, and confirm that the battery pack is the correct model for this charger as shown on the specification chart. Do not charge any other battery pack or any battery pack that does not securely fit the charger.



NOTE: If the battery is hot after continuous use in the tool, allow it to cool down to roomtemperature before charging. This will extend the life of your batteries.



NOTE: Remove battery pack from charger stand which use your thumb or fingers, press the battery's release button in and pull the battery pack off at the same time.

Battery capacity indicator

There are battery capacity indicators on the battery pack; you can check the capacity status of the battery if you squeeze the button. Before using the machine, please press the switch trigger to check if the battery is full enough to properly work.



WARNING: Before making any adjustments ensure the drill is switched off with the direction of rotation selector in the center position.

1. Remove the battery: press the battery release latch in and at the same time pull the battery pack off.
2. To insert the battery, push the battery pack onto the contacts of the tool.

2) Starting the tool

● **Cold starting**

- Switch on the tool by putting the Start/stop button on the position I (ON).
- Push the primer bulb 7-10 times, until fuel comes into the primer bulb.
- Pull the choke lever to the close position. 
- You can choose E-starting, or recoil start.

● **Electric starting**

Press the Electric Start button (22#) 7s max to start the engine. If not start, re-press the Electric Start button (22#) after 3s at least.

Note: the Electric Start button (22#) cannot always be held down if this machine not started, that would damage the starter and battery.

● **Recoil starting**

- Pull the recoil starter handle(31#) until the engine starts.



- Pull the choke lever to the open position.
- Allow the engine to warm up for a few minutes before using.
- Push the safety switch then the throttle trigger to start the operation.

● **Hot starting**

The warm start can be done when the tool was switched off but still hot.

- Switch on the tool by putting the ON/OFF button on the position I (ON).
- Push the primer bulb 7-10 times, until fuel comes into the primer bulb.



- The choke lever must be kept in the open position.  If it is not the case, restart the machine by performing a cold start.

● **Electric starting**

- Press the Electric Start button (22#) until the engine starts.

● **Recoil starting**

- Pull the recoil starter handle (31#) until the engine starts.
- Allow the engine to warm up for a few minutes before using.
- Push the safety switch then the throttle trigger to start the operation.

WARNING! The cutting attachment will engage and rotate as the engine starts and accelerates. If the engine did not continue to run, repeat the appropriate cranking procedure (warm or cold engine). When the engine starts, clear excess fuel from the combustion chamber by revving the engine several times with the throttle trigger (operating the trigger will automatically disengage the "fast idle" setting).

If the engine fails to start, repeat the appropriate starting procedure (warm or cold engine). If the engine fails to start after repeated attempts, the engine is likely flooded. Proceed to the following procedure:

- Disconnect the spark plug lead and then use the spark plug wrench to remove the spark plug (turn counterclockwise to remove).
- If the spark plug is fouled or soaked with fuel, clean the plug.
- Open the choke and fully depress the throttle trigger with your left hand, then pull the starter handle rapidly with your right hand to clear excess fuel from the combustion chamber.

CAUTION! Incorrect spark plug installation can result in serious engine damage

- Reinstall the spark plug and tighten it firmly. If a torque wrench is available, torque the spark plug to 16.7-18.6N.m.
- Repeat the starting procedure.
- If the engine still fails to start inquire with an authorized and qualified service center.

3) Stopping the tool

- Release the throttle trigger and the throttle trigger lockout.
- Let the tool run for a few minutes.
- Move the ON/OFF switch to STOP position (O).

4) Grass trimmer operation

● **Trimming**

Tilt the head slowly to direct debris away from you. If cutting up to a barrier such as fence, wall or tree, approach from an angle where any debris ricocheting off the barrier will fly away from you, Move the line head slowly until the grass is cut right up the barrier, but do not jam (overfeed) the line into the barrier. When trimming up a wire mesh or chain linked fence be careful to feed only up to wire. If you go too far the line will snap off around the wire. Trimming can be done to cut through weed stems one at a time. Place the trimmer line head near the bottom of the weed-never high up which could cause the weed to chatter and catch the line. Rather than cut the weed right through, just use the very end of the line to wear through the stem slowly.

● **Scalping and edging**

Both are done with the line head tilted at a steep angle. Scalping is removing top growth without damaging the ground.

Edging is trimming the grass back where it has spread over a sidewalk or driveway. During both edging and scalping, hold the unit at a steep angle and in a position where the debris, and any dislodging dirt and stones, will not come back towards you even if it ricochets off the hard surface. Although the picture shows how to edge and scalp every operator must find for himself the angles which suit his body size and cutting situation.

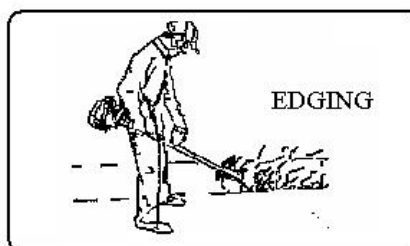
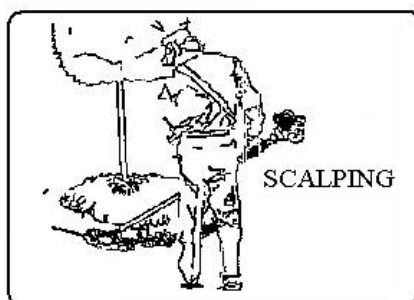

5) Brushcutter operation

- Do not use the brushcutter for cutting trees
- Do not cut with dull, cracked, or damaged blade.

- Before cutting growth, inspect for obstructions such as boulders, metal stakes or strands of wire from broken fences. If an obstruction cannot be removed, mark its location so that you can avoid it with the blade. Rocks and metal will dull or damage a blade. Wire can catch on the blade head and flap around or be thrown into the air.
- Use the shoulder harness at all times adjust both harness and harness clamp on the unit so that the unit hangs a few inches above ground level. The cutting head and the debris shield should be level in all directions. Harness the unit on the right side of your body.
- Cut only with the side of the blade that the debris is moving away from you.
- If kickback occurs, the blade may be dull, or the material so thick and hard that you should use another tool instead of this machine.
- Do not force the blade to cut. Do not change the angle of cut after into the wood. Avoid using any pressure or leverage which could cause the blade to bind or crack.

● **Scything weeds**

This is cutting by swinging the blade in a level arc. It can quickly clear areas of field grass and weeds. Scything should not be used to cut large, tough weeds or woody growths.

Scything can be done in both directions, and just in one way which results in the debris being thrown away from you.

That is using the side of the blade that is rotating away from you. Tilt down the blade slightly on this same side. You will be hit by some debris if you scythe in both directions.

Cut only with the side of the blade that the debris is moving away from you.

If a kickback occurs, the blade may be dull, or the material so thick and hard that you should use another tool instead of this machine.

Do not force the blade to cut. Do not change the angle of cut after into the wood. Avoid using any pressure or leverage which could cause the blade to bind or crack.

8. MAINTENANCE AND STORAGE

Before any maintenance work, the machine must be switched off and completely cooled. Maintenance shall be provided regularly and must be done according to the instructions provided in this instruction manual. A clean, well-maintained machine increases its lifetime and efficiency.

Improper maintenance can cause damage, accidents and render the tool inoperable in the short term.

Any other maintenance, modification or repair must be carried out by a qualified professional.

Do not immerse the tool in water or any other liquid.

1) **Maintenance**

a. **Daily Maintenance**

- Remove all dirt and debris from the engine, check the cooling fins and air cleaner for clogging, and clean, as necessary.
- Carefully remove any accumulating of dirt or debris from the muffler and fuel tank, dirt build-up in these areas can lead to engine overheating, fire, or premature wear.
- Check for loose or missing screws or components. Make sure the cutting attachment is free of debris and securely fastened.
- Check the entire machine for leaking fuel or grease.
- Make sure nuts, bolts, and screws (except carburettor adjusting screws) are tight.

b. **Air filter (10-Hour maintenance)**

Check the air filter as often as necessary to maintain it in a clean condition. Light surface dust can readily be removed by tapping the filter. Heavy deposits should be washed out in a suitable solvent. To clean the filter, unscrew the cover and remove it.

Remove the air cleaner element from the air cleaner housing and clean it thoroughly.

Rinse and dry thoroughly.

Add a few drops of oil, then reassemble the element.

c. Adjusting the carburetor

Do not adjust the carburetor unless necessary. If you have trouble with the carburetor, see your dealer. Improper adjustment may cause engine damage and void warranty.

d. Fuel filter

Fuel tank is fitted with a filter. A filter is situated at the free end of the fuel pipe. It can be picked with a hook or similar device. Check the fuel filter periodically. Do not allow dust to enter the fuel tank. Clogged filter will cause difficulty in starting engine or abnormalities in starting engine or abnormalities in engine performance.

When the filter is dirty, replace the filter. When the inside of the fuel tank is dirty, it can be cleaned by rinsing the tank with gasoline.

e. Spark plug (10-15h maintenance)

The tool must be completely cold before manipulating the spark plug.

- Unplug the cover then remove the spark plug cap
- Clean or replace the spark plug in case of ozone contamination.
- Adjust the spark plug electrode gap to 0.6-0.7mm.
- Replace the spark plug if the end of the centre electrode is worn.

f. Muffler

WARNING! Operating the engine without a muffler or with a muffler that is damaged or improperly installed can increase engine noise sufficiently to lead to hearing loss.

This machine must never be operated with a faulty or missing spark arrestor or muffler.

Make sure the muffler is well secured and in good condition. A worn or damaged muffler is a fire hazard and may also cause hearing loss.

g. Replacement of the cutting string

- Push the tab which is on the housing cutting string and turn the cover to open it (see the markings on the housing).
- Remove the string and replace it by a new one.
- To reinstall the cutting string, first pass the two ends of the string on the holes localized on the housing.
- Put the cutting string in the housing; pull correctly the string outside of the tool in equal part.
- Place the cover on the housing; turn it to lock it in place.

2) Storage

- Inspect and clean the tool as explained in this manual.
- Empty fuel tank (it can be done by switching on the tool and let it consume all remaining fuel).
- Disassemble the accessories.
- Store the main unit and the accessories in a clean area, out of reach of children. It is recommended to place the tool and accessories in the original package.

3) Long Term Storage

Product must be stored in a dry location. Always lock up product and keep out of reach of children. Whenever the machine will not be used for 30 days or longer, use the following procedures to prepare it for storage:

- Clean external parts thoroughly and apply a light coating of oil to all metal surfaces.

CAUTION! Gasoline stored in the carburetor for extended periods can cause hard starting, and could also lead to increased service and maintenance costs.

- Drain all the fuel from the carburetor and the fuel tank.

IMPORTANT! All stored fuel should be stabilized with a fuel stabilizer.

- Remove the spark plug and pour about 3cm³ of oil into the cylinder through the spark plug hole. Slowly pull the recoil starter 2 or 3 times so oil evenly coats the interior of the engine. Reinstall the spark plug.
- Before storing the machine, repair or replace any worn or damaged parts. Make sure the scabbard is in place.
- Remove the air cleaner element from the carburetor and clean it thoroughly
- Rinse and dry thoroughly, then add a few drops of oil and work it in. Reassemble.
- Store the machine in a clean, dust-free area.

9. DISPOSAL

1) Cutting remnants:

Do not throw household rubbish into the environment. Dispose of cutting remnants in rubbish collection centers or seek advice from your local municipality.

2) Tool:

- Do not dispose with household garbage. Do not throw it into the environment.
- Remove oil and fuel from the machine, and dispose them in specific recycling centers.
- Dispose of the product in a waste collection center; or seek advice from your local municipality.
- Proceed with disposal of remnants, tools, accessories, fuel mixture, oil and packaging according to local regulations regarding the protection of the environment.

3) Charger



Electric power tools, as well as their accessories and packaging, must each be able to follow an appropriate recycling pathway. Only for the countries of the European Union:

Do not throw away your electrical appliance with household waste! In accordance with the European Directive 2012/19/EU on waste electrical and electronic equipment and its implementation in national laws, power tools that can no longer be used must be separated and follow an appropriate recycling pathway.

4) BATTERY PACK



This product contains Li-ion. To preserve natural resources, please recycle or dispose of batteries properly. Local, state or federal laws may prohibit disposal of Li-ion batteries in ordinary trash. Consult your local waste authority for information regarding available

Li-ion recycling and/or disposal options.

10. TROUBLESHOOTING

Problems	Causes	Resolutions
The tool cannot be started	The starting process is not followed	Follow the instructions of use of this manual
	Spark plug dirty or moist	Clean the spark plug or replace it by a new one
	Incorrect carburettor adjustment	Contact your dealer or contact SWAP
	Battery power is not enough	Charger the battery Use recoil start
The tool starts but no in a full power	Non-correct setting of the starter	Open the starter
	Air filter is dirty	Clean the air filter
	Incorrect carburettor adjustment	Contact your dealer or contact SWAP
The engine cannot reach its maximal power	Non-correct gap between the electrode and the spark plug	Clean the spark plug and adjust the gap between the electrodes or replace them with a new one
	Incorrect carburettor adjustment	Contact your dealer or contact SWAP
The engine generates of lot of smoke	Incorrect mix of the tank	Do a correct mix of the fuel (see the corresponding chapter)
	Incorrect carburettor adjustment	Contact your dealer or contact SWAP

11. DECLARATION OF CONFORMITY



BUILDER SAS

ZI, 32 RUE ARISTIDE BERGES 31270 CUGNAUX, FRANCE
Tel: +33 (0)534.502.50 Fax: +33 (0)534.502.503

Declares that the machines:

PETROL BRUSH CUTTER & GRASS TRIMMER
RACDBT51ES

Serial No.: 20250200001-20250202065

have been designed in compliance with the following standards:

EN ISO 11806-1 :2022

EN ISO 14982 : 2009

EN62233 :2008

EN60335-2-29:2004+A2:2010+A11:2018

EN60335-1:2012+A11:2014+A13:2017+A1:2019+A2:2019+A14:2019

EN IEC 61000-3-2:2019

EN 61000-3-3:2013+A1:2019:

EN 55014-1:2017+A11:2020

EN 55014-2:2015

And in accordance with the following directives:

Directive Machine 2006/42/EC

Directive EMC 2014/30/EU

Noise Directive 2000/14/EC & Annex V Directive 2005/88/EC

Emission directive (EU) 2016/1628 & 2022/992/EU

Guarantee sound power level: 112 dB(A)

the people name holding the technical file : M. Olivier Patriarca

Philippe MARIE / PDG

Cugnaux, 01/01/2025

12. WARRANTY



WARRANTY

The manufacturer guarantees the product against defects in material and workmanship for a period of 2 years from the date of the original purchase. The warranty only applies if the product is for household use. The warranty does not cover breakdowns due to normal wear and tear.

The manufacturer agrees to replace parts identified as defective by the designated distributor. The manufacturer does not accept responsibility for the replacement of the machine, in whole or in part, and/or ensuing damage.

The warranty does not cover breakdowns due to:

- insufficient maintenance.
- abnormal assembly, adjustment or operations of the product.
- parts subject to normal wear and tear.

The warranty does not extend to:

- shipping and packaging costs.
- using the tool for a purpose other than that for which it was designed.
- the use and maintenance of the machine done in a manner not described in the user manual.

Due to our policy of continuous product improvement, we reserve the right to alter or change specifications without notice. Consequently, the product may be different from the information contained therein, but a modification will be undertaken without notice if it is recognized as an improvement of the preceding characteristic.

READ THE MANUAL CAREFULLY BEFORE USING THE MACHINE.

When ordering spare parts, please indicate the part number or code, you can find this in the spare parts list in this manual. Keep the purchase receipt; without it, the warranty is invalid. To help you with your product, we invite you to contact us by phone or via our website:

- **+33 (0)9.70.75.30.30**
- **<https://services.swap-europe.com/contact>**

You must create a "ticket" via the web platform.

- Register or create your account.
- Indicate the reference of the tool.
- Choose the subject of your request.
- Describe your problem.
- Attach these files: invoice or sales receipt, photo of the identification plate (serial number), photo of the part you need (for example: pins on the transformer plug which are broken).



13. PRODUCT FAILURE

WHAT TO DO IF MY MACHINE BREAKS DOWN?

If you bought your product in a store:

- a) Empty the fuel tank if your product has one.
- b) Make sure that your machine is complete with all accessories supplied, and clean! If this is not the case, the repairer will refuse the machine.

Go to the store with the complete machine and with the receipt or invoice.

If you bought your product on a website:

- a) Empty the fuel tank if your product has one.
- b) Make sure that your machine is complete with all accessories supplied, and clean! If this is not the case, the repairer will refuse the machine.
- c) Create a SWAP-Europe service ticket on the site: <https://services.swap-europe.com> When making the request on SWAP-Europe, you must attach the invoice and the photo of the nameplate (serial number).
- d) Contact the repair station to make sure it is available before dropping off the machine.

Go to the repair station with the complete machine packed, accompanied by the purchase invoice and the station support sheet downloadable after the service request is completed on the SWAP-Europe site

For machines with engine failure from manufacturers BRIGGS & STRATTON, HONDA and RATO, please refer to the following instructions.

Repairs will be done by approved engine manufacturers of these manufacturers, see their site:

- <http://www.briggsandstratton.com/eu/fr>
- <http://www.honda-engines-eu.com/fr/service-network-page;jsessionid=5EE8456CF39CD572AA2AEEDFD290CDAE>
- <https://www.rato-europe.com/it/service-network>

Please keep your original packaging to allow for after-sales service returns or pack your machine with a similar cardboard box of the same dimensions.

For any question concerning our after-sales service you can make a request on our website <https://services.swap-europe.com>

Our hotline remains available at +33 (9) 70 75 30 30.



14. WARRANTY EXCLUSIONS

THE WARRANTY DOES NOT COVER:

- Start-up and setting up of the product.
- Damage resulting from normal wear and tear of the product.
- Damage resulting from improper use of the product.
- Damage resulting from assembly or start-up not in accordance with the user manual.
- Breakdowns related to carburetion beyond 90 days and fouling of carburetors.
- Periodic and standard maintenance events.
- Actions of modification and dismantling that directly void the warranty.
- Products whose original authentication marking (brand, serial number) has been degraded, altered or withdrawn.
- Replacement of consumables.
- The use of non-original parts.
- Breakage of parts following impacts or projections.
- Accessories breakdowns.
- Defects and their consequences linked to any external cause.
- Loss of components and loss due to insufficient screwing.
- Cutting components and any damage related to the loosening of parts.
- Overload or overheating.
- Poor power supply quality: faulty voltage, voltage error, etc.
- Damages resulting from the deprivation of enjoyment of the product during the time necessary for repairs and more generally the costs related to the immobilization of the product.
- The costs of a second opinion established by a third party following an estimate by a SWAP-Europe repair station
- The use of a product which would show a defect or a breakage which was not the subject of an immediate report and/or repair with the services of SWAP-Europe.
- Deterioration linked to transport and storage*.
- Launchers beyond 90 days.
- Oil, petrol, grease.
- Damages related to the use of non-compliant fuels or lubricants.

* In accordance with transport legislation, damage related to transport must be declared to carriers within 48 hours maximum after observation by registered letter with acknowledgement of receipt.

This document is a supplement to your notice, a non-exhaustive list.

Attention: all orders must be checked in the presence of the delivery person. In case of refusal by the delivery person, it you must simply refuse the delivery and notify your refusal.

Reminder: the reserves do not exclude the notification by registered letter with acknowledgement within 72 hours.

Information: Thermal devices must be wintered each season (service available on the SWAP-Europe site). Batteries must be charged before being stored.



BUILDER SAS

32, rue Aristide Bergès - ZI 31270 Cugnaux - France

MADE IN PRC